

Steel Sewer Products

CHAPTER 1

INTRODUCTION

Corrugated steel pipe (CSP) provides a strong, durable, economical selection for the construction of sewer systems. Introduced by a city engineer in 1896, countless miles of CSP now provide reliable service throughout the highway system, and in large and small municipalities across the North American continent.

The sewer designer can select from a wide range of CSP products to meet exacting job requirements. Factory-made pipe, in sizes large enough to accommodate most needs, is available with a variety of corrugation profiles that provide optimal strength. For larger structures, structural plate pipe can be furnished for bolted assembly in the field. Shop fabricated fittings, long lightweight sections, reliable and positive coupling systems—all contribute to speed and economy in field installation. In addition, a range of protective coatings is available to meet rigorous service demands.

CORRUGATED STEEL PIPE AND STRUCTURAL PLATE PIPE DATA

Corrugated Steel Pipe

There are basically two types of corrugated steel pipe: helical and annular.

Helical CSP, where the corrugations and seams run helically around the pipe, is fabricated by:

- a) lockseam method,
- b) continuous welding of the seams,
- c) integrally attaching at the lockseam a helically corrugated steel sheet with a smooth inner steel lining (smooth lined pipe).

Reformed annular ends for joining are available.

Annular CSP, where the corrugations run annularly around the pipe, is fabricated by:

- a) riveting the seams,
- b) bolting the seams,
- c) resistance spot welding the seams.

A wide variety of geometrical shapes are available in corrugated steel pipe to satisfy requirements such as low headroom or greater hydraulic efficiency.

Table 1.1 illustrates the sizes, corrugation profiles, steel thickness and shapes available for the various types of steel pipe.

Handling weights for CSP are shown in Tables 1.2, 1.3, 1.4, 1.5 and 1.6. Tables 1.7 and 1.8 show the design details for corrugated steel pipe-arches.

Structural Plate Pipe

For larger structures requiring field assembly, structural plate pipe is available. Structural plate pipe is fabricated from hot-dip galvanized plates and is assembled by bolting individual plates together to form large pipes, pipe-arches and a variety of other shapes.

Standard sizes of structural plate are indicated in Table 1.1.

Sizes and layout details for circular pipe, pipe-arches and arches are illustrated in Tables 1.9, 1.10 and 1.11.

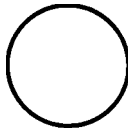

Round

Pipe Arch



Table 1.1 Sizes, Corrugation Profiles, Thickness and Shapes Available for Various Types of Steel Pipe

Type of Pipe	Size (Diameter or Span)		Corrugation Profile		Specified Thickness Range		Shape
	(mm)	(in.)	(mm)	(in.)	(mm)	(in.)	
Corrugated Steel Pipe (Helical and Annular Pipe)	150 - 450	6 - 18	38 x 6.5	1½ x ¼	1.32 - 1.63	.052 - 0.064	Round
	150 - 900	6 - 36	51 x 13	2 x ½	1.32 - 2.01	.052 - .079	Round
	300 - 2400	12 - 96	68 x 13	2⅔ x ½	1.32 - 4.27	.052 - 0.168	Round, Pipe-Arch
	1350 - 3600	54 - 144	75 x 25	3 x 1	1.63 - 4.27	.064 - 0.168	Round
	1350 - 3600	54 - 144	125 x 25*	5 x 1	1.63 - 4.27	.064 - 0.168	Round
	1350 - 3600	54 - 120	75 x 25	3 x 1	2.01 - 4.27	.079 - 0.168	Pipe-arch
	1800 - 3000	72 - 120	125 x 25*	5 x 1	2.77 - 4.27	.109 - 0.168	Pipe-arch
Spiral Rib Pipe	450 - 2400	18 - 96	19x19x190	¾ x ¾ x 7½	1.63 - 2.77	.064 - 0.109	Round, Pipe-Arch
	900 - 2850	36 - 114	19x25x292	¾ x 1x11½	1.63 - 2.77	.004 - 0.109	Round, Pipe-Arch
Structural Plate Pipe	1500 - 8010	5 ft - 26 ft	152 x 51	6 x 2	2.82 - 9.65	0.109 - 0.280	Round, Pipe-Arch Elliptical & Other Special Shapes

Notes: *Available only in helical pipe.

Table 1.2 Corrugated Steel Pipe (CSP) — Round Standard Diameters, End Areas, and Handling Weights 38 mm x 6.5 mm (1½ x ¼ in.) Estimated Average Weights — Not for Specification Use

Inside Diameter		End Area		Approximate Kilograms per Linear Meter (Pounds Per Linear Foot) (Weights will vary slightly with fabrication method)					
				Specified Thickness		Metallic Coated*		Full Bituminous Coated	
(mm)	(in.)	(m²)	(ft²)	(mm)	(in.)	(mm)	(in.)	(mm)	(in.)
150	6	0.018	0.196	1.32	.052	5.8	3.9	7.3	4.9
				1.63	.064	7.1	4.0	8.8	5.9
200	8	0.031	0.349	1.32	.052	7.7	5.2	9.7	6.5
				1.63	.064	9.4	6.3	11.3	7.6
250	10	0.049	0.545	1.32	.052	9.7	6.5	12.0	8.1
				1.63	.064	11.5	7.7	13.8	9.3
300	12	0.071	0.785	1.32	.052	11.3	7.6	14.3	9.6
				1.63	.064	14.0	9.4	17.0	11.4
375	15	0.110	1.227	1.32	.052	14.1	9.5	17.7	11.9
				1.63	.064	17.4	11.7	21.0	14.1
450	18	0.159	1.767	1.32	.052	17.0	11.4	21.3	14.3
				1.63	.064	20.8	14.0	25.1	16.9

Notes: Perforated sub-drains will weigh slightly less.

*Metallic coated: Galvanized or Aluminized

**Table 1.3M Handling Weight of Corrugated Steel Pipe (68 mm x 13 mm)
Estimated Average Weights - Not for Specification Use***

Inside Diameter (mm)	End Area (m ²)	Specified Thickness (mm)	Approximate Kilograms Per Linear Meter**					
			Metallic Coated	Full Bituminous Coated	Full Bituminous Coated and Invert Paved	Bituminous Coated and Full Paved	Steel Lined	Concrete Lined
300	0.07	1.32	12	15	19			
		1.63	15	18	22			
		2.01	18	21	25			
375	0.11	1.32	15	18	22	39		
		1.63	18	22	27	42		
		2.01	22	27	31	46		
450	0.16	1.32	18	21	25	46		
		1.63	22	28	33	51	25	
		2.01	27	33	37	55	30	
525	0.22	1.32	21	24	28	54		
		1.63	25	31	39	61	31	
		2.01	31	37	45	64	36	
600	0.28	1.32	22	25	30	61		
		1.63	28	36	45	67	34	97
		2.01	36	43	52	74	39	103
750	0.44	1.32	30	33	37	76		
		1.63	36	45	54	82	43	122
		2.01	45	54	63	89	51	129
900	0.64	1.32	36	39	43	74		
		1.63	43	54	65	97	52	146
		2.01	54	64	76	112	61	155
		2.77	74	34	96	135		174
		3.51	93	104	115	150		190
1050	0.87	1.32	42	45	49	106		
		1.63	51	63	76	115	63	170
		2.01	63	74	88	126	71	180
		2.77	85	97	111	157		202
		3.51	108	120	133	172		223
1200	1.13	1.32	46	49	54			
		1.63	57	71	85	126	68	190
		2.01	71	86	100	141	79	205
		2.77	97	112	126	180		231
		3.51	123	138	151	195		255
		4.27	150	165	178	232		279
1350	1.43	1.63	65	82	98	141	77	
		2.01	80	97	113	156	88	232
		2.77	109	126	142	195		259
		3.51	138	154	171	232		286
		4.27	168	184	201	262		313
1500	1.77	2.01	89	106	126		101	
		2.77	121	137	158	208	131	286
		3.51	154	171	192	270		318
		4.27	186	202	223	285		348

Notes: Pipe-arch weights will be the same as the equivalent round pipe. For example, for 1060 mm x 740 mm, 68 mm x 13 mm pipe-arch, refer to 900 mm diameter pipe weight.

* Lock seam construction only; weights will vary with other fabrication practices.

** For other coatings or linings, the weights may be interpolated.

**Table 1.3M Handling Weight of Corrugated Steel Pipe (68 mm x 13 mm)
(Cont.) Estimated Average Weights - Not for Specification Use***

Inside Diameter	End Area	Specified Thickness	Approximate Kilograms Per Linear Meter**					
			Metallic Coated	Full Bituminous Coated	Full Bituminous Coated and Invert Paved	Bituminous Coated and Full Paved	Steel Lined	Concrete Lined
(mm)	(m ²)	(mm)						
1650	2.14	2.01	97	115	139			
		2.77	132	150	174	238	143	314
		3.51	168	186	210	267	179	347
		4.27	205	223	247	205		382
1800	2.54	2.77	146	167	192	253	156	
		3.51	183	204	229	313	196	378
		4.27	223	244	270	354		417
1950	2.99	2.77	156	180	205	298	168	
		3.51	198	222	247	342	211	
		4.27	241	265	291	390		453
2100	3.46	2.77	168	198	231	335	180	
		3.51	214	240	266	357	226	
		4.27	259	285	312	405		487
2250	3.98	2.77	181	217	250		195	
		3.51	229	256	286		243	
		4.27	277	304	333	430	292	518
2400	4.52	3.51	244	284	323		259	
		4.27	295	323	339	460	310	552

Notes: Pipe-arch weights will be the same as the equivalent round pipe. For example, for 1060 mm x 740 mm, 68 mm x 13 mm pipe-arch, refer to 900 mm diameter pipe weight.

*Lock seam construction only; weights will vary with other fabrication practices.

** For other coatings or linings, the weights may be interpolated.

**Table 1.3 Handling Weight of Corrugated Steel Pipe (2²/₃ x 1/2 in.)
Estimated Average Weights - Not for Specification Use***

Inside Diameter (in.)	End Area (ft ²)	Specified Thickness (in.)	Approximate Kilograms Per Linear Meter**					
			Metallic Coated	Full Bituminous Coated	Full Bituminous Coated and Invert Paved	Bituminous Coated and Full Paved	Steel Lined	Concrete Lined
12	0.79	0.052	8	10	13			
		0.064	10	12	15			
		0.079	12	14	17			
15	1.23	0.052	10	12	15	26		
		0.064	12	15	18	28		
		0.079	15	18	21	31		
18	1.77	0.052	12	14	17	31		
		0.064	15	19	22	34	17	
		0.079	18	22	25	37	20	
21	2.41	0.052	14	16	19	36		
		0.064	17	21	26	39	21	
		0.079	21	25	30	43	24	
24	3.14	0.052	15	17	20	41		
		0.064	19	24	30	45	23	65
		0.079	24	29	35	50	26	69
30	4.91	0.052	20	22	25	51		
		0.064	24	30	36	55	29	82
		0.079	30	36	42	60	34	87
36	7.07	0.052	24	26	29	50		
		0.064	29	36	44	65	35	98
		0.079	36	43	51	75	41	104
		0.109	49	56	64	90		116
		0.138	62	69	77	100		127
42	9.62	0.052	28	30	33	71		
		0.064	34	42	51	77	42	114
		0.079	42	50	59	85	48	121
		0.109	57	65	74	105		135
		0.138	72	80	89	115		149
48	12.57	0.052	31	33	36			
		0.064	38	48	57	85	46	128
		0.079	48	58	67	95	53	138
		0.109	65	75	84	120		154
		0.138	82	92	101	130		170
		0.168	100	110	119	155		186
54	15.90	0.064	44	55	66	95	52	
		0.079	54	65	76	105	59	156
		0.109	73	84	95	130		173
		0.138	92	103	114	155		191
		0.168	112	123	134	175		209

Notes: Pipe-arch weights will be the same as the equivalent round pipe.
 For example, for 42 x 29, 2²/₃ x 1/2 pipe-arch, refer to 36 in. diameter pipe weight.
 * Lock seam construction only; weights will vary with other fabrication practices.
 ** For other coatings or linings, the weights may be interpolated.

**Table 1.3 Handling Weight of Corrugated Steel Pipe (2²/₃ x 1/2 in.)
(Cont.) Estimated Average Weights — Not for Specification Use***

Inside Diameter (in.)	End Area (ft ²)	Specified Thickness (in.)	Approximate Kilograms Per Linear Meter**					
			Metallic Coated	Full Bituminous Coated	Full Bituminous Coated and Invert Paved	Bituminous Coated and Full Paved	Steel Lined	Concrete Lined
60	19.64	0.079	60	71	85		68	
		0.109	81	92	106	140	88	192
		0.138	103	114	128	180		212
		0.168	124	135	149	190		232
66	23.76	0.079	65	77	93			
		0.109	89	101	117	160	96	211
		0.138	113	125	141	180	120	233
		0.168	137	149	165	210		255
72	28.27	0.109	98	112	129	170	105	
		0.138	123	137	154	210	132	254
		0.168	149	163	180	236		278
78	33.18	0.109	105	121	138	200	113	
		0.138	133	149	166	230	142	
		0.168	161	177	194	260		302
84	38.49	0.109	113	133	155	225	121	
		0.138	144	161	179	240	152	
		0.168	173	190	208	270		325
90	44.18	0.109	121	145	167		130	
		0.138	154	172	192		163	
		0.168	186	204	224	289	196	348
96	50.27	0.138	164	191	217		174	
		0.168	198	217	239	309	208	371

- Notes:** Pipe-arch weights will be the same as the equivalent round pipe.
 For example, for 42 x 29, 2²/₃ x 1/2 pipe-arch, refer to 36 in. diameter pipe weight.
 * Lock seam construction only; weights will vary with other fabrication practices.
 ** For other coatings or linings, the weights may be interpolated.

**Table 1.4M Handling Weight of Corrugated Steel Pipe
(75 mm x 25 mm or 125 mm x 25 mm*)
Estimated Average Weights — Not for Specification Use****

Inside Diameter	End Area	Specified Thickness	Approximate Kilograms Per Linear Meter***					
			Metallic Coated	Full Bituminous Coated	Full Bituminous Coated and Invert Paved	Bituminous Coated and Full Paved	Steel Lined	Concrete Lined
(mm)	(m ²)	(mm)						
1350	1.43	1.63	74	98	125	205	86	293
		2.01	91	115	141	222	100	308
		2.77	124	150	177	256		339
		3.51	159	184	210	291		367
		4.27	193	219	244	325		396
1500	1.77	1.63	82	109	138	228	95	324
		2.01	100	128	156	246	110	341
		2.77	138	165	195	285		367
		3.51	177	204	234	324		408
		4.27	214	241	271	361		439
1650	2.14	1.63	89	119	152	250	104	357
		2.01	110	140	173	269	121	375
		2.77	151	181	214	312		414
		3.51	193	223	256	354		448
		4.27	235	265	298	396		483
1800	2.54	1.63	98	131	165	272	115	390
		2.01	121	152	188	293	132	409
		2.77	165	198	234	340		451
		3.51	210	243	279	385		489
		4.27	256	289	325	432		526
2100	3.46	1.63	115	152	193	317	132	
		2.01	140	177	219	342	155	478
		2.77	192	231	273	396		526
		3.51	246	285	325	450		568
		4.27	298	336	379	502		613
2250	3.98	1.63	115	152	193	317	132	
		2.01	149	189	235	366	165	
		2.77	205	246	292	424	216	564
		3.51	262	303	349	481		609
		4.27	319	360	406	538		657
2400	4.52	1.63	129	173	222	360	152	
		2.01	159	202	251	390	176	
		2.77	20	264	313	453	231	601
		3.51	28	325	375	514		649
		4.27	342	385	435	574		760

Notes: Pipe-arch weights will be the same as the equivalent round pipe. For example, for 2050 mm x 1500 mm, 76 mm x 25 mm pipe-arch, refer to 1800 mm diameter pipe weight
 * 125 mm x 25 mm weighs approximately 12% less than 75 mm x 25 mm
 ** Lock seam construction only; weights will vary with other fabrication practices.
 *** For other coatings or linings, the weights may be interpolated.

**Table 1.4M Handling Weight of Corrugated Steel Pipe
(75 mm x 25 mm or 125 mm x 25 mm*)
(Cont.) Estimated Average Weights — Not for Specification Use****

Inside Diameter	End Area	Specified Thickness	Approximate Kilograms Per Linear Meter***					Concrete Lined
			Metallic Coated	Full Bituminous Coated	Full Bituminous Coated and Invert Paved	Bituminous Coated and Full Paved	Steel Lined	
(mm)	(m ²)	(mm)						
2550	5.11	1.63	138	185	235	384	161	639
		2.01	170	216	266	415	188	
		2.77	232	283	330	480	246	
		3.51	297	343	394	554	690	
		4.27	361	408	459	609	744	
2700	5.73	1.63	155	207	262	430	180	730
		2.01	179	228	280	439	198	
		2.77	247	297	349	510	259	
		3.51	316	366	418	579	787	
		4.27	384	433	486	646		
2850	6.38	1.63	155	207	262	430	180	771
		2.01	199	254	313	490	220	
		2.77	272	327	385	563	287	
		3.51	333	385	441	610	874	
		4.27	426	481	540	718		
3000	7.07	1.63	163	219	274	444	190	811
		2.01	201	256	315	483	222	
		2.77	274	330	388	567	289	
		3.51	351	406	465	643	874	
		4.27	426	481	540	718		
3150	7.79	2.01	210	266	327	515	231	302
		2.77	290	347	408	595		
		3.51	370	427	489	678		
3300	8.55	2.01	220	280	344	540	243	317
		2.77	304	363	427	624		
		3.51	388	448	513	711		
		4.27	471	531	595	793		
3450	9.35	2.01	229	292	359	564	251	329
		2.77	317	379	446	652		
		3.51	405	468	535	742		
		4.27	492	555	622	829		
3600	10.18	2.77	332	397	467	682	345	436
		3.51	420	485	555	769		
		4.27	516	582	652	868		

Notes: Pipe-arch weights will be the same as the equivalent round pipe. For example, for 2050 mm x 1500 mm, 75 mm x 25 mm pipe-arch, refer to 1800 mm diameter pipe weight.

* 125 mm x 25 mm weighs approximately 12% less than 75 mm x 25 mm

** Lock seam construction only; weights will vary with other fabrication practices.

*** For other coatings or linings, the weights may be interpolated.

**Table 1.4 Handling Weight of Corrugated Steel Pipe (3 x 1 in. or 5 x 1in.*)
Estimated Average Weights — Not for Specification Use****

Inside Diameter	End Area	Specified Thickness	Approximate Pounds Per Linear Foot***					
			Metallic Coated	Full Bituminous Coated	Full Bituminous Coated and Invert Paved	Bituminous Coated and Full Paved	Steel Lined	Concrete Lined
(in.)	(ft ²)	(in.)						
54	15.9	0.064	50	66	84	138	58	197
		0.079	61	77	95	149	67	207
		0.109	83	100	118	171		226
		0.138	106	123	140	194		245
		0.168	129	146	163	217		264
60	19.6	0.064	55	73	93	153	64	218
		0.079	67	86	105	165	74	229
		0.109	92	110	130	190		251
		0.138	118	136	156	216		272
		0.168	143	161	181	241		293
66	23.8	0.064	60	80	102	168	70	240
		0.079	74	94	116	181	81	252
		0.109	101	121	143	208		276
		0.138	129	149	171	236		299
		0.168	157	177	199	264		322
72	28.3	0.064	66	88	111	183	77	262
		0.079	81	102	126	197	89	275
		0.109	110	132	156	227		301
		0.138	140	162	186	257		326
		0.168	171	193	217	288		351
84	38.5	0.064	77	102	130	213	89	
		0.079	94	119	147	230	104	321
		0.109	128	154	182	264		351
		0.138	164	189	217	300		379
		0.168	199	224	253	335		409
90	44.2	0.064	82	109	140	228	96	
		0.079	100	127	158	246	111	
		0.109	137	164	195	283	144	376
		0.138	175	202	233	321		406
		0.168	213	240	271	359		438
96	50.3	0.064	87	116	149	242	102	
		0.079	107	136	169	262	118	
		0.109	147	176	209	302	154	401
		0.138	188	217	250	343		433
		0.168	228	257	290	383		467

Notes: Pipe-arch weights will be the same as the equivalent round pipe. For example: for 81 x 59, 3 x 1 in. pipe-arch, refer to 72 in. diameter pipe weight.

*5 x 1 in. weighs approximately 12% less than 3 x 1 in.

**Lock seam construction only, weights will vary with other fabrication practices.

***For other coatings or linings the weights may be interpolated.

**Table 1.4 Handling Weight of Corrugated Steel Pipe (3 x 1 in. or 5 x 1 in.*)
(Cont.) Estimated Average Weights — Not for Specification Use****

Inside Diameter	End Area	Specified Thickness	Approximate Pounds Per Linear Foot***					Steel Lined	Concrete Lined
			Metallic Coated	Full Bituminous Coated	Full Bituminous Coated and Invert Paved	Bituminous Coated and Full Paved			
(in.)	(ft ²)	(in.)							
102	56.8	0.064	93	124	158	258	108	426 460 496	
		0.079	114	145	179	279	126		
		0.109	155	189	220	320	164		
		0.138	198	229	263	363			
		0.168	241	272	306	406			
108	63.6	0.064	98	131	166	273	115	487 525	
		0.079	120	153	188	295	133		
		0.109	165	198	233	340	173		
		0.138	211	244	279	386			
		0.168	256	289	324	431			
114	70.9	0.064	104	139	176	289	121	514 583	
		0.079	127	162	199	312	141		
		0.109	174	209	246	359	183		
		0.138	222	257	294	407			
		0.168	284	321	360	479			
120	78.5	0.064	109	146	183	296	127	541 583	
		0.079	134	171	210	329	148		
		0.109	183	220	259	378	193		
		0.138	234	271	310	429			
		0.168	284	321	360	479			
126	86.6	0.079	141	179	220	346	155		
		0.109	195	233	274	400	203		
		0.138	247	285	326	452			
132	95.0	0.079	148	188	231	363	163		
		0.109	204	244	287	419	213		
		0.138	259	299	342	474			
		0.168	314	354	397	529			
138	103.9	0.079	154	196	241	379	169		
		0.109	213	255	300	438	221		
		0.138	270	312	357	495			
		0.168	328	370	415	553			
144	113.1	0.109	223	267	314	458	232		
		0.138	282	326	373	517	293		
		0.168	344	388	435	579			

Notes: Pipe-arch weights will be the same as the equivalent round pipe. For example: for 81 x 59, 3 x 1 in. pipe-arch, refer to 72 in. diameter pipe weight.

*5 x 1 in. weighs approximately 12% less than 3 x 1 in.

**Lock seam construction only, weights will vary with other fabrication practices.

***For other coatings or linings the weights may be interpolated.

**Table 1.5 End Areas and Handling Weights of Spiral Rib Pipe
19 mm x 19 mm rib at 190 mm (3/4 x 3/4 x 7 1/2 in.) and
19 mm x 25 mm Rib at 292 mm (3/4 x 1 x 11 1/2 in.)
Estimated Average Weights — Not for Specification Use***

Inside Diameter		End Area		Specified Thickness		Approximate Kilograms Per Linear Meter** (Pounds Per Linear Foot)					
						Metallic Coated		Full Bituminous Coated		Full Bituminous Coated and Invert Paved	
(mm)	(in.)	(m ²)	(ft ²)	(mm)	(in.)	(kg/m)	(lbs/ft)	(kg/m)	(lbs/ft)	(kg/m)	(lbs/ft)
450	18	0.16	1.8	1.63	.064	22	15	28	19	30	20
				2.01	.079	27	18	33	22	34	23
525	21	0.22	2.4	1.63	.064	25	17	31	21	33	22
				2.01	.079	31	21	37	25	39	26
				2.77	.109	43	29	49	33	49	33
600	24	0.28	3.1	1.63	.064	30	19	37	24	39	25
				2.01	.079	36	24	43	29	44	32
				2.77	.109	54	36	61	41	63	42
750	30	0.44	4.9	1.63	.064	37	24	46	30	49	32
				2.01	.079	46	30	55	36	58	38
				2.77	.109	63	42	71	48	74	50
900	36	0.64	7.1	1.63	.064	45	29	55	36	58	38
				2.01	.079	55	36	65	43	68	45
				2.77	.109	74	50	85	57	88	59
1050	42	0.87	9.6	1.63	.064	52	33	64	41	67	43
				2.01	.079	64	42	76	50	79	52
				2.77	.109	86	58	98	66	90	60
1200	48	1.13	12.6	1.63	.064	60	38	74	48	77	50
				2.01	.079	73	48	88	58	91	60
				2.77	.109	100	66	115	76	118	78
1350	54	1.43	15.9	1.63	.064	67	43	83	54	86	56
				2.01	.079	82	54	98	65	101	67
				2.77	.109	112	75	128	86	131	88
1500	60	1.77	19.6	1.63	.064	74	48	92	60	95	62
				2.01	.079	91	60	109	72	112	74
				2.77	.109	124	83	141	95	144	97
1650	66	2.14	23.8	1.63***	.064	79	53	99	66	102	68
				2.01	.079	99	66	118	79	121	81
				2.77	.109	136	91	156	104	159	106
1800	72	2.54	28.1	2.01	.079	109	72	129	86	134	89
				2.77	.109	149	99	170	113	174	116
1950	78	2.99	33.2	2.01	.079	118	78	140	93	144	96
				2.77	.109	161	108	171	115	176	118
2100	84	3.46	38.5	2.01***	.079	106	71	131	101	135	104
				2.77	.109	173	116	198	133	202	136
2250	90	3.98	44.2	2.77	.109	186	124	214	143	220	147
2400	96	4.52	50.3	2.77	.109	198	132	228	152	234	156
2550	102	5.11	56.8	2.77	.109	210	141	243	163	249	167
2700	108	5.73	63.6	2.77***	.109	223	150	256	172	262	176

Notes: * Lock seam construction only.
 ** For other coatings or linings, the weights may be interpolated.
 *** For 19 mm x 25 mm rib at 292 mm (3/4 x 1 x 11 1/2 in.) only.

Perforated Pipe

Corrugated steel pipe is available with perforations for collection or dissemination of water underground. Most fabricators are equipped to furnish 10 mm ($\frac{3}{8}$ in.) round holes. Other sizes and configurations are available.

The most common standard pattern is 320 - 10 mm (30 - $\frac{3}{8}$ in. per square foot) round holes per square meter of pipe surface. See Chapter 6 for design requirements.

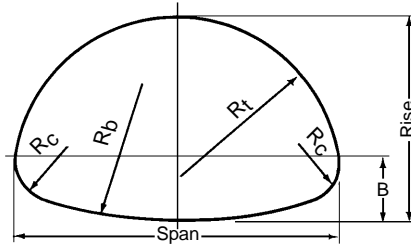

Table 1.6M Sizes and Layout Details — CSP Pipe-Arches
(68 mm x 13 mm Corrugation)

Equiv. Diameter	Design		Waterway Area	Layout Dimensions			
	Span	Rise		B	Rc	Rt	Rb
(mm)	(mm)	(mm)	(m ²)	(mm)	(mm)	(mm)	(mm)
375	430	330	0.10	105	90	220	650
450	530	380	0.15	125	105	275	840
525	610	460	0.20	145	125	300	880
600	710	510	0.27	165	140	355	1075
750	885	610	0.42	205	175	455	1400
900	1060	740	0.60	250	210	545	1680
1050	1240	840	0.83	290	245	640	1960
1200	1440	970	1.08	330	280	725	2240
1350	1620	1100	1.37	370	315	820	2520
1500	1800	1200	1.68	415	350	910	2800
1650	1950	1320	2.03	455	385	1000	3080
1800	2100	1450	2.42	495	420	1090	3360

Notes: Dimensions shown are not for specification purposes, subject to manufacturing tolerances.

Table 1.6 Sizes and Layout Details — CSP Pipe-Arches
(2 $\frac{1}{8}$ x $\frac{1}{2}$ in. Corrugation)

Equiv. Diameter	Design		Waterway Area	Layout Dimensions			
	Span	Rise		B	Rc	Rt	Rb
(in.)	(in.)	(in.)	(ft ²)	(in.)	(in.)	(in.)	(in.)
15	17	13	1.1	4 $\frac{1}{8}$	3 $\frac{1}{2}$	8 $\frac{5}{8}$	25 $\frac{5}{8}$
18	21	15	1.6	4 $\frac{1}{8}$	4 $\frac{1}{8}$	10 $\frac{3}{4}$	33 $\frac{3}{8}$
21	24	18	2.2	5 $\frac{5}{8}$	4 $\frac{7}{8}$	11 $\frac{1}{8}$	34 $\frac{5}{8}$
24	28	20	2.9	6 $\frac{1}{2}$	5 $\frac{1}{2}$	14	42 $\frac{1}{4}$
30	35	24	4.5	8 $\frac{1}{8}$	6 $\frac{7}{8}$	17 $\frac{1}{8}$	55 $\frac{1}{8}$
36	42	29	6.5	9 $\frac{3}{4}$	8 $\frac{1}{4}$	21 $\frac{1}{2}$	66 $\frac{1}{8}$
42	49	33	8.9	11 $\frac{3}{8}$	9 $\frac{5}{8}$	25 $\frac{1}{8}$	77 $\frac{1}{4}$
48	57	38	11.6	13	11	28 $\frac{5}{8}$	88 $\frac{1}{4}$
54	64	43	14.7	14 $\frac{7}{8}$	12 $\frac{7}{8}$	32 $\frac{1}{4}$	99 $\frac{1}{4}$
60	71	47	18.1	16 $\frac{1}{4}$	13 $\frac{3}{4}$	35 $\frac{3}{4}$	110 $\frac{1}{4}$
66	77	52	21.9	17 $\frac{7}{8}$	15 $\frac{1}{8}$	39 $\frac{3}{8}$	121 $\frac{1}{4}$
72	83	57	26.0	19 $\frac{1}{2}$	16 $\frac{1}{2}$	43	132 $\frac{1}{4}$

Notes: Dimensions shown are not for specification purposes, subject to manufacturing tolerances.

**Table 1.7M Sizes and Layout Details — CSP Pipe-Arches
(125 mm x 25 mm and 76 mm x 25 mm Corrugation)**

Equiv. Diameter	Nominal Size	Design		Waterway Area	Layout Dimensions			
		Span	Rise		B	Rc	Rt	Rb
(mm)	(mm)	(m ²)	(mm)	(m ²)	(mm)	(mm)	(mm)	(mm)
1200	1340 x 1050	1340	1050	1.09	385	260	715	1865
1350	1520 x 1170	1485	1235	1.45	520	475	745	1300
1500	1670 x 1300	1650	1375	1.79	580	525	830	1430
1650	1850 x 1400	1840	1480	2.16	640	580	935	1620
1800	2050 x 1500	2005	1585	2.56	605	530	1005	2100
1950	2200 x 1620	2195	1710	2.98	655	575	1100	2345
2100	2400 x 1720	2370	1825	3.44	705	620	1195	2545
2250	2600 x 1820	2575	1935	3.94	755	665	1300	2835
2400	2840 x 1920	2755	2045	4.46	805	705	1395	3055
2550	2970 x 2020	2955	2155	5.04	855	750	1510	3345
2700	3240 x 2100	3135	2270	5.62	905	795	1605	3550
2850	3470 x 2220	3325	2385	6.26	955	840	1710	3795
3000	3600 x 2320	3515	2490	6.92	1005	885	1820	4125
3150	3800 x 2440	3705	2595	7.52	1040	915	1930	4370
3300	3980 x 2570	3885	2720	8.27	1090	965	2030	4570
3450	4160 x 2670	4035	2875	9.10	1145	1015	2085	4675
3600	4340 x 2790	4190	3010	9.94	1195	1040	2160	4825

Notes: Dimensions shown are not for specification purposes, subject to manufacturing tolerances.

**Table 1.7 Sizes and Layout Details — CSP Pipe-Arches
(3 x 1 or 5 x 1 in. Corrugation)**

Equiv. Diameter	Nominal Size	Design		Waterway Area	Layout Dimensions			
		Span	Rise		B	Rc	Rt	Rb
(in.)	(in.)	(in.)	(in.)	(ft ²)	(in.)	(in.)	(in.)	(in.)
48	53 x 41	53	41	11.7	15 ¹ / ₄	10 ³ / ₁₆	28 ⁷ / ₁₆	73 ¹ / ₁₆
54	60 x 46	58 ¹ / ₂	48 ¹ / ₂	15.6	20 ¹ / ₂	18 ⁷ / ₄	29 ⁷ / ₈	51 ¹ / ₈
60	66 x 51	65	54	19.3	22 ³ / ₄	20 ³ / ₄	32 ³ / ₈	56 ¹ / ₄
66	73 x 55	72 ¹ / ₂	58 ¹ / ₄	23.2	25 ¹ / ₈	22 ¹ / ₈	36 ³ / ₄	63 ³ / ₄
72	81 x 59	79	62 ¹ / ₂	27.4	23 ³ / ₄	20 ⁷ / ₈	39 ¹ / ₂	82 ³ / ₈
78	87 x 63	86 ¹ / ₂	67 ¹ / ₄	32.1	25 ³ / ₄	22 ³ / ₈	43 ³ / ₈	92 ¹ / ₄
84	95 x 67	93 ¹ / ₂	71 ³ / ₄	37.0	27 ³ / ₄	24 ³ / ₈	47	100 ¹ / ₄
90	103 x 71	101 ¹ / ₂	76	42.4	29 ³ / ₄	26 ¹ / ₈	51 ¹ / ₄	111 ¹ / ₈
96	112 x 75	108 ¹ / ₂	80 ¹ / ₂	48.0	31 ³ / ₈	27 ³ / ₄	54 ⁷ / ₈	120 ¹ / ₄
102	117 x 79	116 ¹ / ₂	84 ³ / ₄	54.2	33 ³ / ₈	29 ¹ / ₂	59 ³ / ₈	131 ¹ / ₄
108	128 x 83	123 ¹ / ₂	89 ¹ / ₄	60.5	35 ³ / ₈	31 ¹ / ₄	63 ³ / ₄	139 ³ / ₄
114	137 x 87	131	93 ³ / ₄	67.4	37 ³ / ₈	33	67 ³ / ₈	149 ¹ / ₂
120	142 x 91	138 ¹ / ₂	98	74.5	39 ¹ / ₂	34 ³ / ₄	71 ³ / ₈	162 ³ / ₈
126	150 x 96	146	102	81	41	36	76	172
132	157 x 101	153	107	89	43	38	80	180
138	164 x 105	159	113	98	45	40	82	184
144	171 x 110	165	118 ¹ / ₂	107	47	41	85	190

Notes: Dimensions shown are not for specification purposes, subject to manufacturing tolerances.

**Table 1.8 Size and Layout Details — Structural Plate Circular Pipe
152 mm x 51 mm (6 x 2 in.) Corrugation Profile**

Inside Diameter		Waterway Area		Periphery Total	
(mm)	(ft-in.)	(m ²)	(ft ²)	N	Pi
1500	5-0	1.77	19.6	20	60
1665	5-6	2.16	23.7	22	66
1810	6-0	2.58	28.3	24	72
1965	6-6	3.04	33.2	26	78
2120	7-0	3.54	38.5	28	84
2275	7-6	4.07	44.2	30	90
2430	8-0	4.65	50.2	32	96
2585	8-6	5.26	56.7	34	102
2740	9-0	5.91	63.6	36	108
2895	9-6	6.60	70.8	38	114
3050	10-0	7.32	78.5	40	120
3205	10-6	8.09	86.5	42	126
3360	11-0	8.89	95.0	44	132
3515	11-6	9.73	103.8	46	138
3670	12-0	10.61	113.0	48	144
3825	12-6	11.52	122.7	50	150
3980	13-0	12.47	132.7	52	156
4135	13-6	13.46	143.1	54	162
4290	14-0	14.49	153.9	56	168
4445	14-6	15.56	165.0	58	174
4600	15-0	16.66	176.6	60	180
4755	15-6	17.81	188.6	62	186
4910	16-0	18.99	201.0	64	192
5065	16-6	20.20	213.7	66	198
5220	17-0	21.46	226.9	68	204
5375	17-6	22.75	240.4	70	210
5530	18-0	24.08	254.3	72	216
5685	18-6	25.46	268.7	74	222
5840	19-0	26.86	283.4	76	228
5995	19-6	28.31	298.5	78	234
6150	20-0	29.79	314.0	80	240
6305	20-6	31.31	329.9	82	246
6460	21-0	32.87	346.2	84	252
6615	21-6	34.47	362.9	86	258
6770	22-0	36.10	379.9	88	264
6925	22-6	37.77	397.4	90	270
7080	23-0	39.48	415.3	92	276
7235	23-6	41.23	433.5	94	282
7390	24-0	43.01	452.2	96	288
7545	24-6	44.84	471.2	98	294
7700	25-0	46.70	490.6	100	300
7855	25-6	48.60	510.4	102	306
8010	26-0	50.53	530.7	104	312

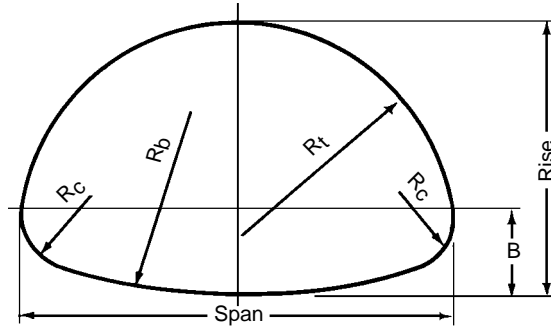

Table 1.9M Structural Plate Pipe-Arch Size and Layout Details 152 mm x 51 mm Corrugation — Bolted Seams 457 mm Corner Radius, Rc

Dimensions		Waterway Area	Layout Dimensions			Periphery Total	
Span	Rise		B	Rt	Rb	N	Pi
(mm)	(mm)	(m ²)	(mm)	(mm)	(mm)		
1850	1400	2.04	530	940	1940	22	66
1930	1450	2.23	520	970	2500	23	69
2060	1500	2.42	560	1040	2120	24	72
2130	1550	2.60	540	1080	2650	25	75
2210	1600	2.88	530	1110	3460	26	78
2340	1650	3.07	570	1180	2790	27	81
2410	1700	3.25	550	1210	3500	28	84
2490	1750	3.53	530	1240	4650	29	87
2620	1800	3.72	580	1320	3580	30	90
2690	1850	3.99	550	1350	4540	31	93
2840	1910	4.27	600	1430	3670	32	96
2900	1960	4.55	580	1460	4510	33	99
2970	2010	4.83	560	1480	5790	34	102
3120	2060	5.11	610	1560	4530	35	105
3250	2110	5.39	660	1650	3890	36	108
3330	2160	5.67	640	1670	4580	37	111
3480	2210	5.95	700	1760	4010	38	114
3530	2260	6.22	670	1780	4650	39	117
3610	2310	6.60	640	1810	5500	40	120
3760	2360	6.87	700	1900	4740	41	123
3810	2410	7.25	670	1920	5510	42	126
3860	2460	7.53	640	1940	6540	43	129
3910	2540	7.90	610	1960	7990	44	132
4090	2570	8.27	670	2050	6470	45	135
4240	2620	8.64	730	2140	5600	46	138
4290	2670	9.01	700	2160	6450	47	141
4340	2720	9.38	670	2180	7560	48	144
4520	2770	9.75	730	2280	6460	49	147
4670	2820	10.12	800	2370	5760	50	150
4720	2870	10.50	770	2390	6500	51	153
4780	2920	10.96	730	2400	7400	52	156
4830	3000	11.33	700	2430	8590	53	159
5000	3020	11.71	760	2520	7390	54	162
5050	3070	12.17	730	2540	8450	55	165

Notes: Dimensions are to inside crests and are subject to manufacturing tolerances. N = 3 Pi = 244 mm

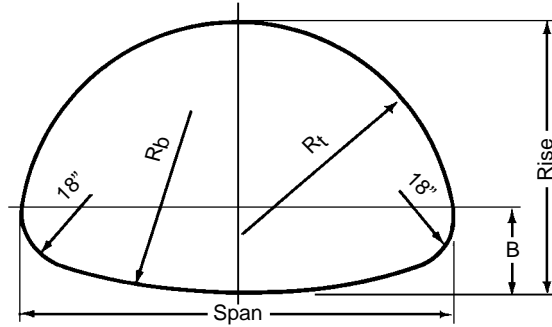

Table 1.9 Structural Plate Pipe-Arch Size and Layout Details 6 x 2 in. Corrugation — Bolted Seams 18-inch Corner Radius, R_c

Dimensions		Waterway Area	Layout Dimensions			Periphery Total	
Span	Rise		B	R _t	R _b	N	Pi
(ft-in.)	(ft-in.)	(ft ²)	(in.)	(ft)	(ft)		
6-1	4-7	22	21.0	3.07	6.36	22	66
6-4	4-9	24	20.5	3.18	8.22	23	69
6-9	4-11	26	22.0	3.42	6.96	24	72
7-0	5-1	28	21.4	3.53	8.68	25	75
7-3	5-3	31	20.8	3.63	11.35	26	78
7-8	5-5	33	22.4	3.88	9.15	27	81
7-11	5-7	35	21.7	3.98	11.49	28	84
8-2	5-9	38	20.9	4.08	15.24	29	87
8-7	5-11	40	22.7	4.33	11.75	30	90
8-10	6-1	43	21.8	4.42	14.89	31	93
9-4	6-3	46	23.8	4.68	12.05	32	96
9-6	6-5	49	22.9	4.78	14.79	33	99
9-9	6-7	52	21.9	4.86	18.98	34	102
10-3	6-9	55	23.9	5.13	14.86	35	105
10-8	6-11	58	26.1	5.41	12.77	36	108
10-11	7-1	61	25.1	5.49	15.03	37	111
11-5	7-3	64	27.4	5.78	13.16	38	114
11-7	7-5	67	26.3	5.85	15.27	39	117
11-10	7-7	71	25.2	5.93	18.03	40	120
12-4	7-9	74	27.5	6.23	15.54	41	123
12-6	7-11	78	26.4	6.29	18.07	42	126
12-8	8-1	81	25.2	6.37	21.45	43	129
12-10	8-4	85	24.0	6.44	26.23	44	132
13-5	8-5	89	26.3	6.73	21.23	45	135
13-11	8-7	93	28.9	7.03	18.39	46	138
14-1	8-9	97	27.6	7.09	21.18	47	141
14-3	8-11	101	26.3	7.16	24.80	48	144
14-10	9-1	105	28.9	7.47	21.19	49	147
15-4	9-3	109	31.6	7.78	18.90	50	150
15-6	9-5	113	30.2	7.83	21.31	51	153
15-8	9-7	118	28.8	7.89	24.29	52	156
15-10	9-10	122	27.4	7.96	28.18	53	159
16-5	9-11	126	30.1	8.27	24.24	54	162
16-7	10-1	131	28.7	8.33	27.73	55	165

Notes: Dimensions are to inside crests and are subject to manufacturing tolerances. N = 3 Pi = 9.6 in.

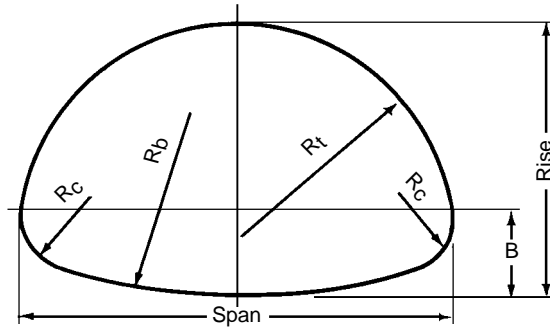

Table 1.10M Structural Plate Pipe-Arch Size and Layout Details 152 mm x 51mm Corrugation — Bolted Seams 787 mm Corner Radius, R_c

Dimensions		Waterway Area	Layout Dimensions			Periphery Total	
Span	Rise		B	R_t	R_b	N	Pi
(mm)	(mm)	(m ²)	(mm)	(mm)	(mm)		
4040	2840	9.0	980	2040	4890	46	138
4110	2900	9.5	960	2070	5590	47	141
4270	2950	9.8	1010	2140	5030	48	144
4320	3000	10.1	990	2170	5650	49	147
4390	3050	10.6	960	2200	6520	50	150
4550	3100	11.0	1010	2280	5790	51	153
4670	3150	11.4	1060	2370	5300	52	156
4750	3200	11.8	1040	2390	5890	53	159
4830	3250	12.3	1020	2420	6620	54	162
4950	3300	12.7	1070	2500	6000	55	165
5030	3350	13.2	1040	2530	6680	56	168
5180	3400	13.6	1100	2620	6120	57	171
5230	3450	14.0	1070	2640	6780	58	174
5310	3510	14.6	1050	2660	7570	59	177
5460	3560	15.0	1100	2750	6870	60	180
5510	3610	15.5	1080	2770	7610	61	183
5660	3660	16.0	1140	2860	6970	62	186
5720	3710	16.4	1110	2880	7680	63	189
5870	3760	16.9	1170	2970	7080	64	192
5940	3810	17.5	1140	3000	7750	65	195
5990	3860	18.0	1110	3020	8550	66	198
6070	3910	18.6	1080	3040	9510	67	201
6220	3960	19.0	1140	3130	8590	68	204
6270	4010	19.6	1110	3150	9490	69	207

Notes: Dimensions are to inside crests and are subject to manufacturing tolerances. $N = 3 \text{ Pi} = 244 \text{ mm}$

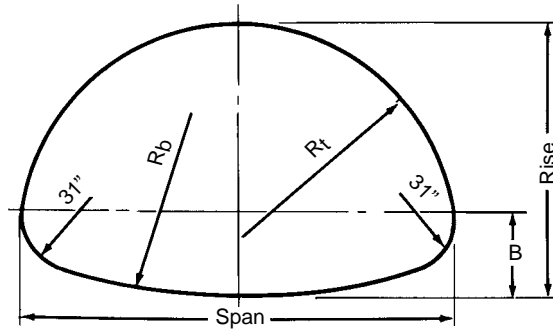

Table 1.10 Structural Plate Pipe-Arch Size and Layout Details 6 x 2 in. Corrugation — Bolted Seams 31 in. Corner radius, R_c

Dimensions		Waterway Area (ft ²)	Layout Dimensions			Periphery Total	
Span (ft-in.)	Rise (ft-in.)		B (in.)	R _t (ft)	R _b (ft)	N	Pi
13-3	9-4	97	38.5	6.68	16.05	46	138
13-6	9-6	102	37.7	6.78	18.33	47	141
14-0	9-8	105	39.6	7.03	16.49	48	144
14-2	9-10	109	38.8	7.13	18.55	49	147
14-5	10-0	114	37.9	7.22	21.38	50	150
14-11	10-2	118	39.8	7.48	18.98	51	153
15-4	10-4	123	41.8	7.76	17.38	52	156
15-7	10-6	127	40.9	7.84	19.34	53	159
15-10	10-8	132	40.0	7.93	21.72	54	162
16-3	10-10	137	42.1	8.21	19.67	55	165
16-6	11-0	142	41.1	8.29	21.93	56	168
17-0	11-2	146	43.3	8.58	20.08	57	171
17-2	11-4	151	42.3	8.65	22.23	58	174
17-5	11-6	157	41.3	8.73	24.83	59	177
17-11	11-8	161	43.5	9.02	22.55	60	180
18-1	11-10	167	42.4	9.09	24.98	61	183
18-7	12-0	172	44.7	9.38	22.88	62	186
18-9	12-2	177	43.6	9.46	25.19	63	189
19-3	12-4	182	45.9	9.75	23.22	64	192
19-6	12-6	188	44.8	9.83	25.43	65	195
19-8	12-8	194	43.7	9.90	28.04	66	198
19-11	12-10	200	42.5	9.98	31.19	67	201
20-5	13-0	205	44.9	10.27	28.18	68	204
20-7	13-2	211	43.7	10.33	31.13	69	207

Notes: Dimensions are to inside crests and are subject to manufacturing tolerances. $N = 3 \text{ Pi} = 9.6 \text{ in.}$

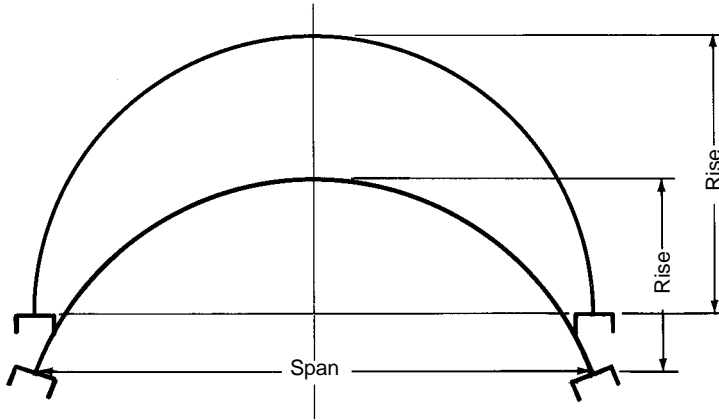

Table 1.11M Structural Plate – Representative Sizes 152 mm x 51 mm Corrugation – Bolted Seams

Inside Dimensions*		Waterway Area**	Rise over Span***	Radius	Periphery Total	
Span	Rise				N	Pi
(mm)	(mm)	(m ²)		(mm)		
1830	550	0.70	0.30	1040	9	27
	700	1.16	0.38	950	10	30
	970	1.39	0.53	910	12	36
2130	710	1.11	0.34	1140	11	33
	860	1.39	0.40	1090	12	36
	1120	1.86	0.53	1070	14	42
2440	640	1.58	0.37	1300	13	39
	1020	1.86	0.42	1230	14	42
	1270	2.42	0.52	1220	16	48
2740	640	1.72	0.32	1500	14	42
	1180	2.46	0.43	1400	16	48
	1440	3.07	0.53	1370	18	54
3050	1050	2.32	0.35	1630	16	48
	1350	3.16	0.44	1540	18	54
	1600	3.81	0.52	1520	20	60
3350	1070	2.55	0.32	1850	17	51
	1360	3.44	0.41	1710	19	57
	1750	4.65	0.52	1680	22	66
3660	1230	3.25	0.34	1970	19	57
	1520	4.18	0.42	1850	21	63
	1910	5.48	0.52	1830	24	72
3960	1240	3.53	0.32	2200	20	60
	1550	4.55	0.39	2040	23	66
	2060	6.50	0.52	1980	26	78
4270	1410	4.65	0.33	2310	22	66
	1700	5.39	0.40	2180	24	72
	2210	7.43	0.52	2130	28	84
4570	1410	4.65	0.31	2590	23	69
	1730	5.76	0.38	2360	25	75
	2010	6.97	0.44	2310	27	81
	2360	8.55	0.52	2290	30	90

Notes: * Dimensions are to inside crests and are subject to manufacturing tolerances.
 ** End area under soffit above spring line.
 *** R/S ratio varies from 0.30 to 0.53. Intermediate spans and rises are available.

**Table 1.11M Structural Plate – Representative Sizes 152 mm x 51 mm
(Cont.) Corrugation – Bolted Seams**

Inside Dimensions*		Waterway Area**	Rise over Span***	Radius	Periphery Total	
Span (mm)	Rise (mm)				N	Pi
4880	1570	5.57	0.32	2670	25	75
	2160	7.99	0.45	2460	29	87
	2510	9.75	0.52	2440	32	96
5180	1590	5.85	0.31	2920	26	78
	2180	8.55	0.42	2620	30	90
	2690	11.06	0.52	2590	34	96
5490	1750	6.97	0.32	3020	28	84
	2340	9.66	0.43	2770	32	96
	2720	11.71	0.50	2740	35	111
5790	1930	8.08	0.33	3120	30	90
	2490	10.96	0.43	2920	34	102
	2880	13.01	0.50	2900	37	111
6100	1930	8.45	0.32	3380	31	93
	2530	11.52	0.42	3100	35	105
	3050	14.59	0.50	3050	39	123
6400	2110	9.66	0.33	3480	33	99
	2690	13.00	0.42	3250	37	111
	3200	15.98	0.50	3200	41	123
6710	2110	10.13	0.31	3710	34	102
	2720	13.56	0.40	3430	38	114
	3350	17.65	0.50	3350	43	129
7010	2440	12.45	0.35	3730	37	117
	3000	15.89	0.43	3560	41	123
	3510	19.32	0.50	3510	45	135
7320	2590	13.94	0.35	3860	39	117
	3150	17.47	0.43	3710	43	129
	3660	21.00	0.50	3660	47	141
7620	2600	14.40	0.34	4060	40	120
	3310	19.23	0.43	3860	45	135
	3810	22.95	0.50	3810	49	147

Notes: * Dimensions are to inside crests and are subject to manufacturing tolerances.

** End area under soffit above spring line.

***R/S ratio varies from 0.30 to 0.53. Intermediate spans and rises are available.

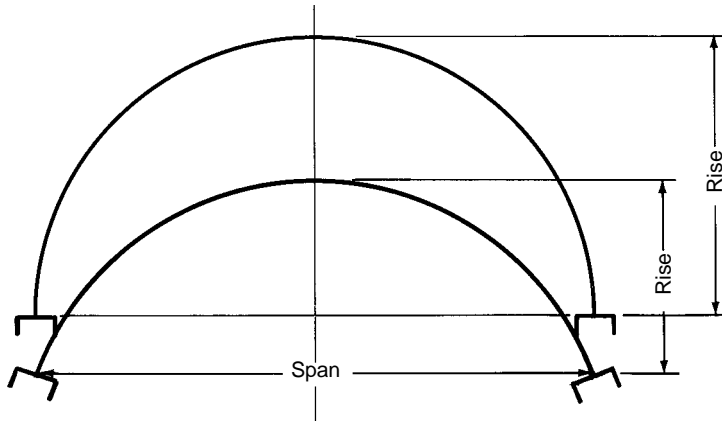

**Table 1.11 Structural Plate Arch — Representative Sizes
6 x 2 in. Corrugation — Bolted Seams**

Inside Dimensions*		Waterway Area**	Rise Over Span***	Radius	Periphery Total	
Span	Rise				N	Pi
(ft)	(ft-in.)	(ft ²)		(in.)		
6.0	1-9/2	7 1/2	0.30	41	9	27
	2-3 1/2	10	0.38	37 1/2	10	30
	3-2	15	0.53	36	12	36
7.0	2-4	12	0.34	45	11	33
	2-10	15	0.40	43	12	36
	3-8	20	0.52	42	14	42
8.0	2-11	17	0.37	51	13	39
	3-4	20	0.42	48 1/2	14	42
	4-2	26	0.52	48	16	48
9.0	2-11	18 1/2	0.32	59	14	42
	3-10 1/2	26 1/2	0.43	55	16	48
	4-8 1/2	33	0.52	54	18	54
10.0	3-5 1/2	25	0.35	64	16	48
	4-5	34	0.44	60 1/2	18	54
	5-3	41	0.52	60	20	60
11.0	3-6	27 1/2	0.32	73	17	51
	4-5 1/2	37	0.41	67 1/2	19	57
	5-9	50	0.52	66	22	66
12.0	4-0 1/2	35	0.34	77 1/2	19	57
	5-0	45	0.42	73	21	63
	6-3	59	0.52	72	24	72
13.0	4-1	38	0.32	86 1/2	20	60
	5-1	49	0.39	80 1/2	22	66
	6-9	70	0.52	78	26	78
14.0	4-7 1/2	47	0.33	91	22	66
	5-7	58	0.40	86	24	72
	7-3	80	.052	84	28	84

Notes: * Dimensions are to inside crests and are subject to manufacturing tolerances.

** End area under soffit above spring line.

*** R/S ratio varies from 0.30 to 0.53. Intermediate spans and rises are available.

Table 1.11 Structural Plate Arch — Representative Sizes (Cont.) 6 x 2 in. Corrugation — Bolted Seams

Inside Dimensions*		Waterway Area**	Rise Over Span***	Radius	Nominal Arc Length	
Span	Rise				N	Pi
(ft)	(ft-in.)	(ft ²)		(in.)		
15.0	4-7½	50	0.31	101	23	69
	5-8	62	0.38	93	25	75
	6-7	75	0.44	91	27	81
	7-9	92	0.52	90	30	90
16.0	5-2	60	0.32	105	25	75
	7-1	86	0.45	97	29	87
	8-3	105	0.52	96	32	96
17.0	5-2½	63	0.31	115	26	78
	7-2	92	0.42	103	30	90
	8-10	119	0.52	96	34	96
18.0	5-9	75	0.32	119	28	84
	7-8	104	0.43	109	32	96
	8-11	126	0.50	114	35	111
19.0	6-4	87	0.33	123	30	90
	8-2	118	0.43	115	34	102
	9-5½	140	0.50	114	37	111
20.0	6-4	91	0.32	133	31	93
	8-3½	124	0.42	122	35	105
	10-0	157	0.50	126	39	123
21.0	6-11	104	0.33	137	33	99
	8-10	140	0.42	128	37	111
	10-6	172	0.50	126	41	123
22.0	6-11	109	0.31	146	34	102
	8-11	146	0.40	135	38	114
	11-0	190	0.50	132	43	129
23.0	8-0	134	0.35	152	37	117
	9-10	171	0.43	140	41	123
	11-6	208	0.50	138	45	135
24.0	8-6	150	0.35	152	39	117
	10-4	188	0.43	146	43	129
	12-0	226	0.50	144	47	141
25.0	8-6½	155	0.34	160	40	120
	10-10½	207	0.43	152	45	135
	12-6	247	0.50	150	49	147

Notes: * Dimensions are to inside crests and are subject to manufacturing tolerances.

** End area under soffit above spring line.

***R/S ratio varies from 0.30 to 0.53. Intermediate spans and rises are available.

Arch Channels

For arch seats, galvanized unbalanced channels with anchor lugs are available. See Figure 1.1 below.

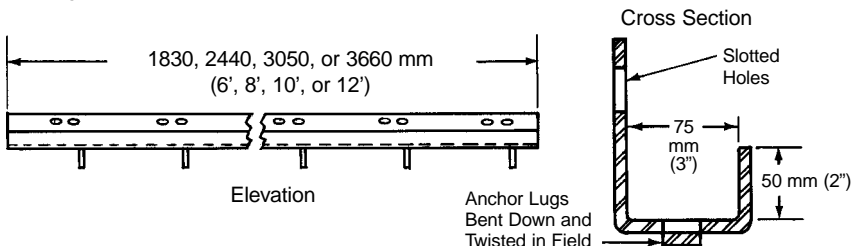
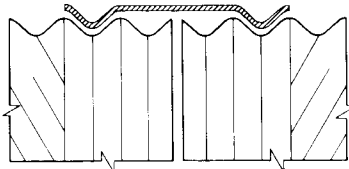
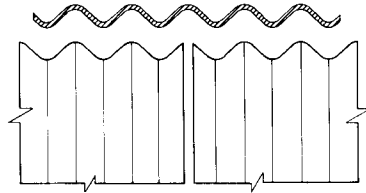

Figure 1.1 General dimensions of unbalanced channels for structural plate arches.

Soil-Tight Couplers



Semi-Corrugated (Hugger)



Corrugated (Annular)

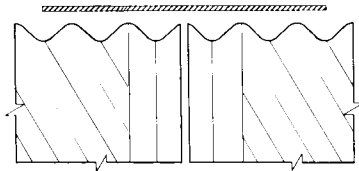

Flat

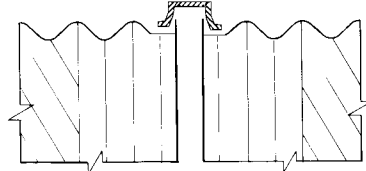

Hat

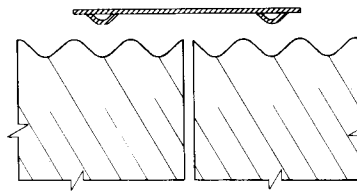

Universal*

*Unless a dimple fills each corrugation valley, a suitable gasket or geotextile wrap is required

Water-Tight Couplers

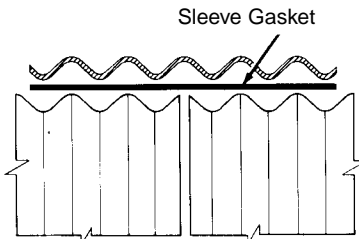

Corrugated (Anular)

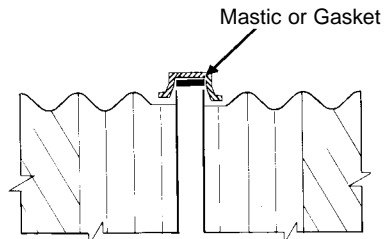

Hat

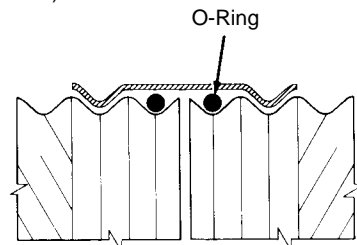

Semi-Corrugated (Hugger)

CSP COUPLING SYSTEMS

The functional requirements for pipe joints are specified in the AASHTO Bridge Design Specification, Section 26.4.2. The design of field joints using these criteria is covered in Chapter 7.

A wide variety of pipe joints are available for field connecting lengths of corrugated steel pipe. The drawings on the previous page illustrate and define the standard joints which can be classified as Soil-tight and Watertight. Other equally effective couples may be designed and supplied based on specific project needs.

Soil-tight Conditions







Couplers need to be soil-tight to keep backfill from infiltrating into the pipe. However, the specifier must first consider the backfill surrounding the coupler along with the flow conditions the pipe will experience. Very fine, granular backfill materials such as silty sands can infiltrate into a pipe. Conversely, course materials, such as a minimum stone are too large to infiltrate. Clayey materials, with a plastic index greater than 12 are generally too well adhered to infiltrate. In applications where flow increases and decreases quickly, water that has exfiltrated into the backfill, infiltrates back into the pipe and might carry with it fine backfill particles.

Generally, there is no need for concern with a coupling system that utilizes re-rolled or annular ends. However, when pipe is buried in a silt or fine sand backfill situation and flows rise and fall quickly, soil-tight considerations are necessary. See AASHTO Section 26.4.2.4(e).

Watertight Conditions

Watertight couplers are rarely required. Any watertight requirements are dictated by specific project conditions such as when the pipe system is located below the groundwater table or when it is carrying hazardous pollutants. Watertight coupling systems should be prequalified through laboratory testing to avoid installation influences on performance and eliminate time consuming and extremely expensive field-testing.

Table 1.12 Coupling Bands For Corrugated Steel Pipe

Type of Band	Cross Section	Angles	Bar Bolt, & Strap	Gaskets			Pipe End		
				O-Ring	Sleeve or Strip	Mastic	Annular Plain	Helical	
								Plain	Reformed
Universal		X	X		X	X	X	X	X
Corrugated		X	X		X	X	X	X	X
Semi-Corrugated		X	X	X		X	X	X	
Channel		X	X	X		X	X		X
Flat		X	X	X	X	X	X	X	X
Wing Channel		X	X			X			

Standard CSP Gaskets



O-Ring Gasket

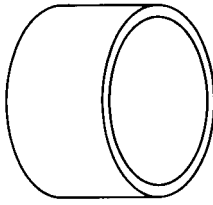

Sleeve Gasket

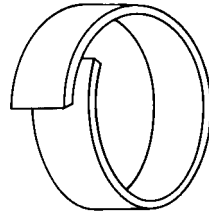

Strip Gasket or
Geotextile Wrap

Standard CSP Band Connectors

The following band connectors are used with CSP coupling systems:

Band Angle Connector

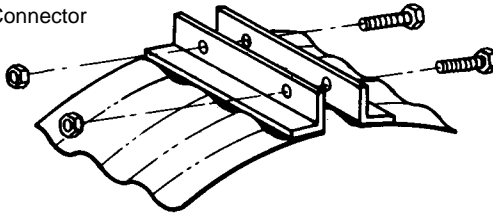

Clip or Lug Angle Connector

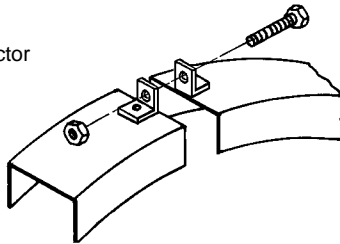

Bar and Strap Connector

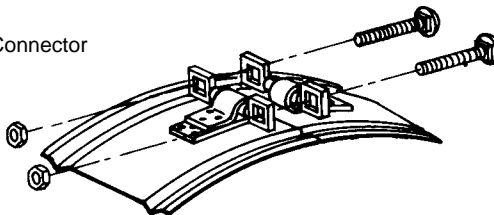

For unusual conditions (i.e., high pressures, extreme disjuncting forces, threading pipe inside existing pipe, jacking or boring pipe, and deep vertical drop inlets), a variety of special designs are available or a new special joint may be designed by the manufacturer to meet a new requirement.

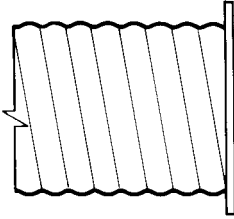

Flat Joint

Bolted Flanges are attached to pipe ends.

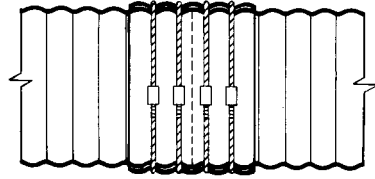

Rod & Lug

Band is secured by rod around band connected by lugs.

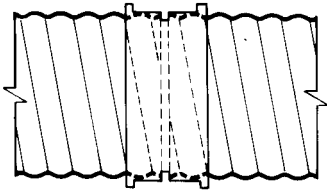

Sleeve Joint

Smooth sleeve with center stop. Stab type joint.

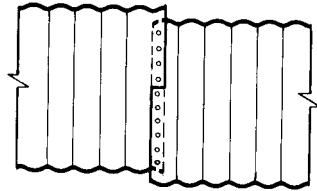

Jacking or Threading

Boring-Pipe slit, stabs together, may be bolted if required.

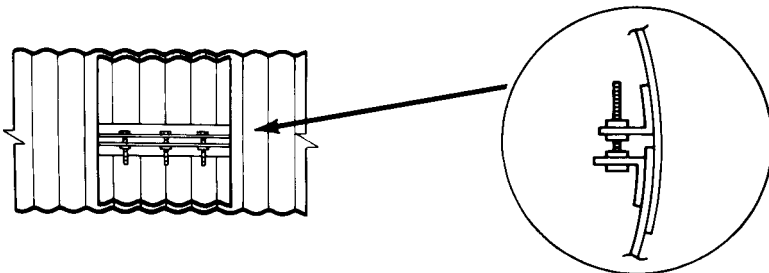

Internal Type

CSP FITTINGS AND SEWER APPURTENANCES

An important feature of corrugated steel pipe sewers is the wide range of fittings and appurtenances that can be employed. The nature of the material makes possible almost any special fitting that can be designed. When possible, it is generally most economical to use the most commonly produced or “standard” fittings. To guide the designer, presented herein are the typical fittings and appurtenances fabricated throughout the country.

Sewer system hardware such as grates, manhole covers, ladders and steps are easily incorporated in corrugated steel manholes or inlets. The following pages illustrate how this hardware is used in corrugated steel structures.

Fittings

Tables 1.13, 1.14 and 1.15 list the standard or minimum dimensions of common fittings and elbows. Note that these are minimum dimensions. It may be most practical in some cases to fabricate fittings with longer legs than those shown here. It is ordinarily best to let the contractor and supplier work out such details. However, it may be useful for the designer to have these minimum dimensions in laying out turns or intersections where precision is required.

Pipe sizes larger than those shown in these tables should be individually designed. The larger sizes can require longer leg dimensions, depending on wall thickness and type of pipe fabrication.



Manifold system used for underground detention.

**Table 1.13M Minimum Dimensions for Elbows for Round CSP (mm)
All Corrugations**

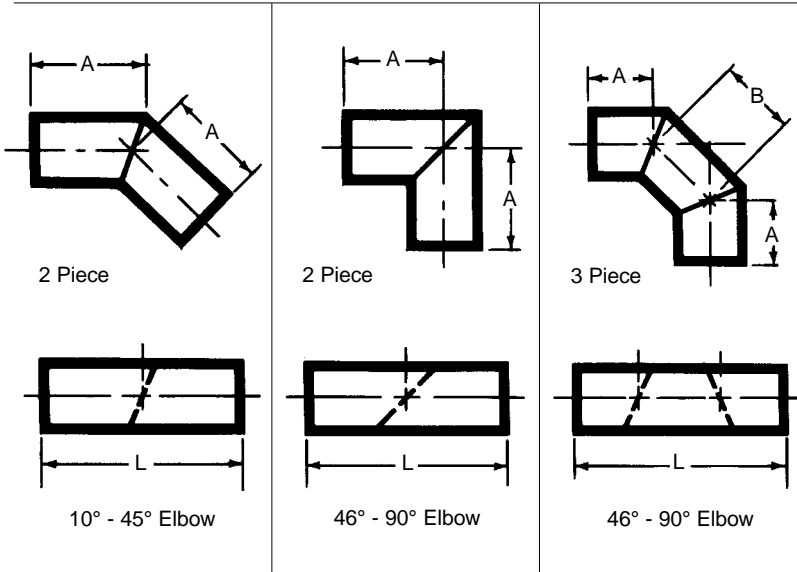

Pipe Diameter (mm)	A (mm)	Total Length (mm)	Pipe Diameter (mm)	A (mm)	Total Length (mm)	Pipe Diameter (mm)	A (mm)	B (mm)	C (mm)	Total Length (mm)
150 - 450	300	600	150 - 250	300	600	150	340	200	200	600
525 - 1200	600	1200	300 - 675	600	1200	200	360	230	190	600
1350 - 2400	900	1800	750 - 1050	900	1800	250	360	250	180	600
			1200 - 1650	1200	2400	300	650	280	470	1200
			1800 - 2400	1500	3000	375	670	300	470	1200
			2250 - 2400	1800	6000	450	690	360	460	1200
						525	690	380	430	1200
						600	700	410	420	1200
						675	700	430	410	1200
						750	1020	480	670	1800
						825	1020	510	660	1800
						900	1030	530	650	1800
						1050	1040	580	620	1800
						1200	1360	660	890	2400
						1350	1370	710	860	2400
						1500	1380	790	830	2400
						1650	1370	840	800	2400
						1800	1710	910	1070	3000
						1950	1730	990	1030	3000
						2100	1740	1040	1000	3000
						2250	1780	1170	940	3000
						2400	2080	1170	1240	3600

Notes: The total length (mm) and pipe diameter (mm) listed are minimum requirements for fitting fabrication. Fittings with other dimensions to satisfy specific needs are also available. All dimensions are nominal. **All dimensions are in millimeters.**

**Table 1.13 Minimum Dimensions for Elbows for Round CSP
All Corrugations**

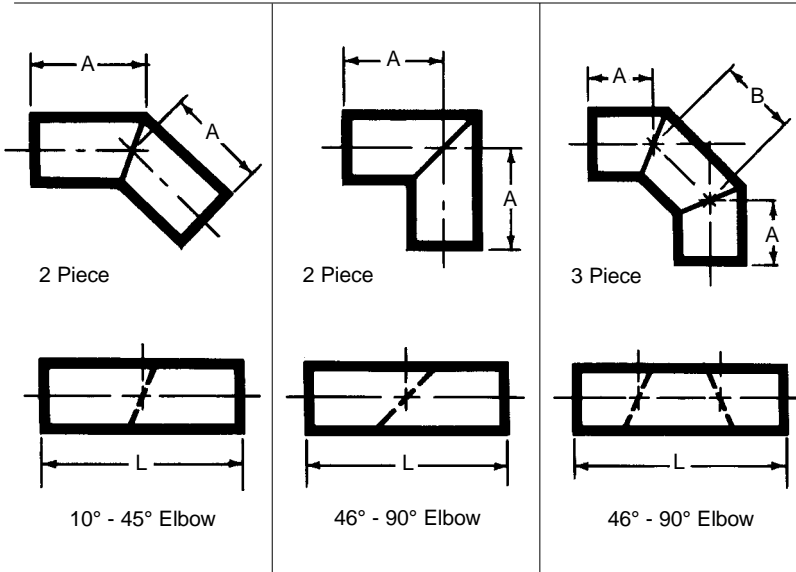

Pipe Diameter (in.)	A (ft)	Total Length (ft)	Pipe Diameter (in.)	A (ft)	Total Length (ft)	Pipe Diameter (in.)	A (in.)	B (in.)	C (in.)	Total Length (ft)
6-18	1	2	6-10	1	2	6	13½	8	8	2
21-48	2	4	12-27	2	4	8	14	9	7½	2
54-96	3	6	30-42	3	6	10	14	10	7	2
			48-66	4	8	12	25½	11	18½	4
			72-84	5	10	15	26½	12	18	4
			90-96	6	12	18	27	14	17	4
						21	27	15	16½	4
						24	27½	16	16	4
						27	27½	17	15½	4
						30	40	19	26½	6
						33	40	20	26	6
						36	40½	21	25½	6
						42	41	23	24½	6
						48	53½	26	35	8
						54	54	28	34	8
						60	54½	31	32½	8
						66	54	33	31½	8
						72	67½	36	42	10
						78	68	39	40½	10
						84	68½	41	39½	10
						90	70	46	37	10
						96	82	46	49	12

Notes: The total length (ft) and pipe diameter (in.) listed are minimum requirements for fitting fabrication. Fittings with other dimensions to satisfy specific needs are also available. All dimensions are nominal.

Table 1.14M Minimum Dimensions for CSP Round Fittings (mm)

Main Diam. (mm)	Stub Same or Smaller Than Main Diameter										45° Wye		
	Tee			Cross			45° Lateral				A	B	TL
	A	B	TL	A	B	TL	A	B	C	TL			
150	600	600	1200	600	600	1200	600	600	200	1200	600	600	1800
200	600	600	1200	600	600	1200	600	600	200	1200	600	600	1800
250	600	600	1000	600	600	1200	1200	600	430	1800	600	600	1800
300	1200	600	1800	1200	1200	2400	1200	600	430	1800	600	600	1800
375	1200	600	1800	1200	1200	2400	1200	1200	460	2400	600	600	1800
450	1200	600	1800	1200	1200	2400	1200	1200	330	2400	600	600	1800
525	1200	600	1800	1200	1200	2400	1500	900	560	2400	600	600	1800
600	1200	600	1800	1200	1200	2400	1800	1200	580	3000	600	600	1800
675	1200	600	1800	1200	1200	2400	1800	1200	510	3000	600	600	1800
750	1200	600	1800	1200	1200	2400	1800	1200	530	3000	600	600	1800
825	1800	1200	3000	1800	1800	3600	1800	1800	480	3600	600	900	2400
900	1800	1200	3000	1800	1800	3600	2400	1800	460	4200	600	900	2400
1050	1800	1200	3000	1800	1800	3600	2400	1800	530	4200	600	900	2400
1200	1800	1200	3000	1800	1800	3600	3000	2400	460	4800	600	900	2400
1350	1800	1200	3000	1800	1800	3600	3000	2400	580	5400	1200	1200	3600
1650	2400	1200	3600	2400	2400	4800	3600	3600	810	6600	1200	1200	3600
1800	2400	1200	3600	2400	2400	4800	4200	3000	1140	7200	1200	1500	4200
1950	3000	1800	4500	3000	3000	6000	4800	3600	1170	8400	1200	1500	4200
2100	3000	1800	4500	3000	3000	6000	4800	3600	1190	8400	1200	1500	4200
2250	3000	1800	4500	3000	3000	6000	4800	3600	1240	8400	1200	1500	4200
2400	3000	1800	4800	3000	3000	6000	4800	3600	1270	8400	1200	1800	4800

Notes: TL - total net length needed to fabricate fitting
All dimensions are in millimeters.

Table 1.14 Minimum Dimensions for CSP Round Fittings (in., ft)

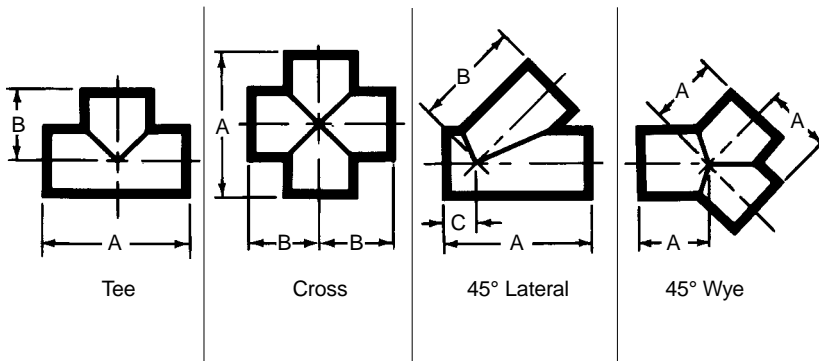

Main Diam.	Stub Same or Smaller Than Main Diameter										45° Wye		
	Tee			Cross			45° Lateral						
	A	B	TL	A	B	TL	A	B	C	TL	A	B	TL
(in.)	(ft)	(ft)	(ft)	(ft)	(ft)	(ft)	(ft)	(ft)	(in.)	(ft)	(ft)	(ft)	(ft)
6	2	2	4	2	2	4	2	2	8	4	2	2	6
8	2	2	4	2	2	4	2	2	8	4	2	2	6
10	2	2	4	2	2	4	4	2	17	6	2	2	6
12	4	2	6	4	4	8	4	2	17	6	2	2	6
15	4	2	6	4	4	8	4	4	18	8	2	2	6
18	4	2	6	4	4	8	4	4	13	8	2	2	6
21	4	2	6	4	4	8	6	4	22	10	2	2	6
24	4	2	6	4	4	8	6	4	23	10	2	2	6
27	4	2	6	4	4	8	6	4	20	10	2	2	6
30	4	2	6	4	4	8	6	4	21	10	2	2	6
33	6	4	10	6	6	12	6	6	19	12	2	3	8
36	6	4	10	6	6	12	8	6	19	14	2	3	8
42	6	4	10	6	6	12	8	6	21	14	2	3	8
48	6	4	10	6	6	12	10	8	28	18	2	3	8
54	6	4	10	6	6	12	10	8	23	18	4	4	12
60	8	4	12	8	8	16	12	10	30	22	4	4	12
66	8	4	12	8	8	16	12	10	32	22	4	4	12
72	8	4	12	8	8	16	14	10	45	24	4	5	14
78	10	6	16	10	10	20	14	10	46	24	4	5	14
84	10	6	16	10	10	20	16	12	47	28	4	5	14
90	10	6	16	10	10	20	16	12	49	28	4	5	14
96	10	6	16	10	10	20	16	12	50	28	4	6	16

Notes: TL - total net length needed to fabricate fitting.

Table 1.15M Minimum Dimensions for CSP Pipe-Arch Elbow Fittings

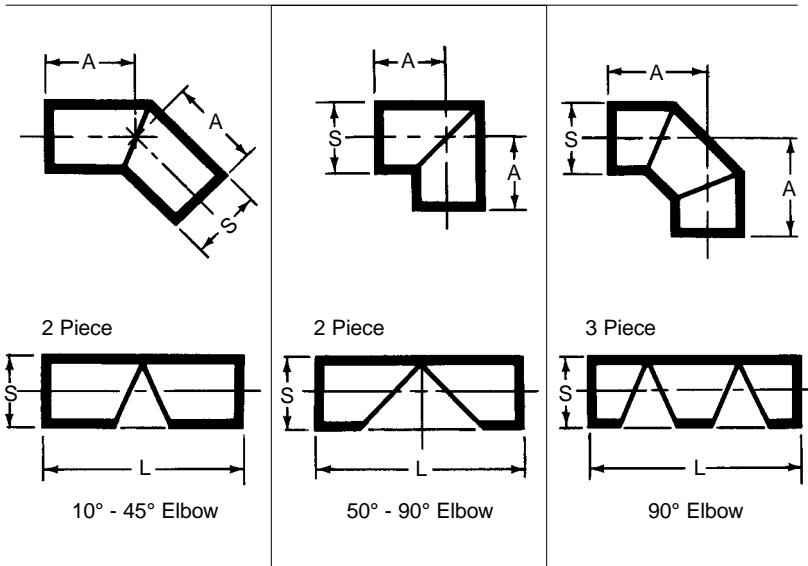
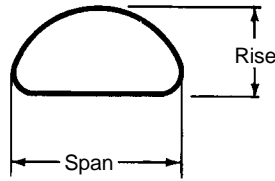

Equivalent Round Diameter (mm)	Span S (mm)	Rise R (mm)	45° Elbow 2 Piece		90° Elbow 2 Piece		90° Elbow 3 Piece	
			A (mm)	L (mm)	A (mm)	L (mm)	A (mm)	L (mm)
375	430	330	510	1200	690	1800	790	1800
450	530	380	510	1200	640	1800	760	1800
525	610	460	480	1200	610	1800	740	1800
600	710	510	460	1200	860	2400	710	1800
750	885	610	410	1200	760	2400	970	2400
900	1060	740	690	1800	970	3000	890	2400
1050	1240	840	640	1800	890	3000	1140	3000
1200	1440	970	610	1800	1090	3600	1060	3000
1350	1620	1100	860	2400	1320	4200	1320	3600
1500	1800	1200	840	2400	1520	4800	1570	4200
1650	1950	1320	1090	3000	1420	4800	1520	4200
1800	2100	1450	1070	3000	1420	5400	1780	4800

Notes: All dimensions are nominal
L—length for fabrication

Table 1.15 Minimum Dimensions for CSP Pipe-Arch Elbow Fittings

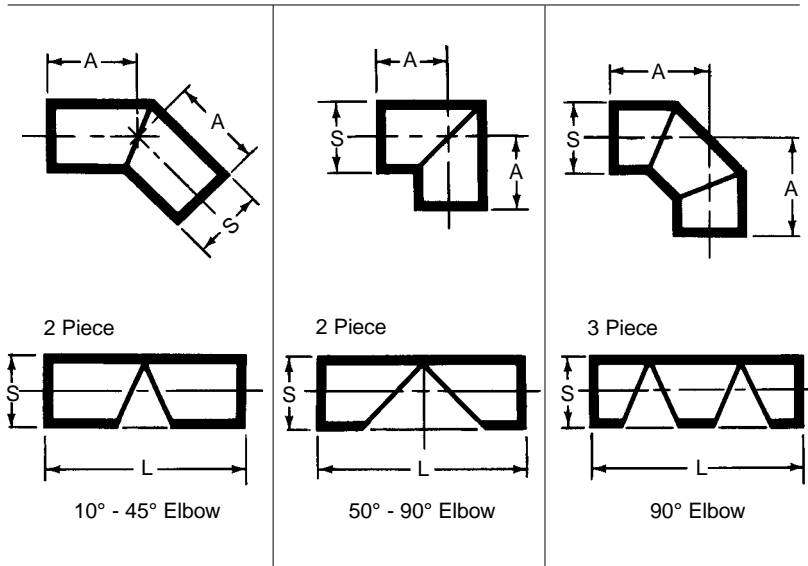
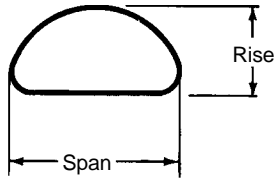

Equivalent Round Diameter	Span S	Rise R	45° Elbow 2 Piece		90° Elbow 2 Piece		90° Elbow 3 Piece	
			A	L	A	L	A	L
(in.)	(in.)	(in.)	(in.)	(ft)	(in.)	(ft)	(in.)	(ft)
15	17	13	20	4	27	6	31	6
18	21	15	20	4	25	6	30	6
21	24	18	19	4	24	6	29	6
24	28	20	18	4	34	8	28	6
30	35	24	16	4	30	8	38	8
36	42	29	27	6	38	10	35	8
42	49	33	25	6	35	10	45	10
48	57	38	24	6	43	12	42	10
54	64	43	34	8	52	14	52	12
60	71	47	33	8	60	16	62	14
66	77	52	43	10	56	16	60	14
72	83	57	42	10	56	18	70	16

Notes: All dimensions are nominal
L—length for fabrication

Saddle Branch

Saddle branches are used to connect smaller branch lines to the main. Saddles make it practical to accurately tie in connections after the main line is laid. Or, new connections can be effectively made on old lines with saddles. Saddles can be used to connect almost any type of pipe to a CSP main. A common “universal” type of saddle branch stub to do this is shown below.

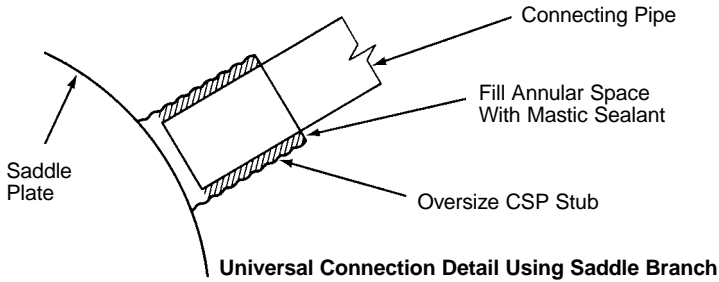

Typical pre-fabricated CSP saddle branch fitting used in connecting house laterals or incoming pipe from catch basins.

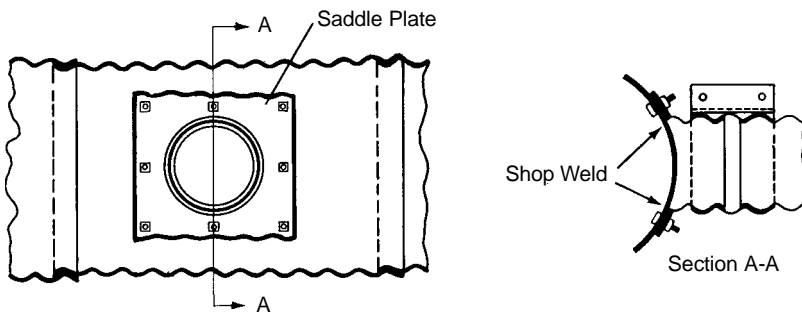

Figure 1.2 Saddle branch, bolted to main sewer on the job or at the plant, enables laterals and house connections to join the sewer.

Transitions

Changes in pipe diameter should be accomplished in junction structures. However, there are circumstances when a pipe reducer or enlarger section is desired.

A simple, instant size change can be done as shown in Figure 1.3.

Tapered transitions may be fabricated in smooth steel for helical pipe systems as shown in Figure 1.4. Reinforcement may be required.

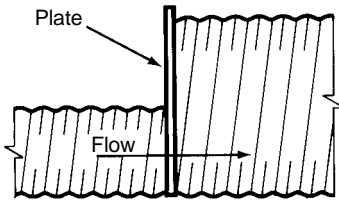

Figure 1.3 Enlarger

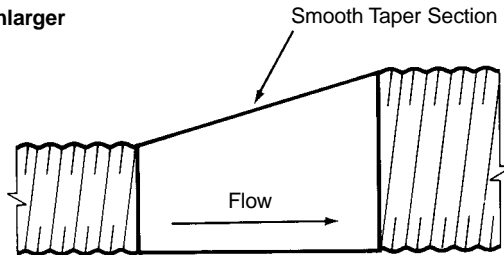

Figure 1.4 Eccentric Transition



Saddle branch manhole is bolted to sewer conduit while riser extension is being lowered and coupled.

Manholes and Catch Basins

Manholes are available in corrugated pipe construction in two basic types as shown below. The riser type of manhole is the simpler of the two and quite economical. It is only feasible for trunk lines of 900 mm (36 in.) diameter or greater. When junctions of smaller diameters are involved, it is possible to use a vertical shaft of larger diameter CSP to connect the sewers. However, when the shaft is greater than 900 mm (36 in.) in diameter, some reduction detail must be used to suit the cover. Typical reduction details are shown below.

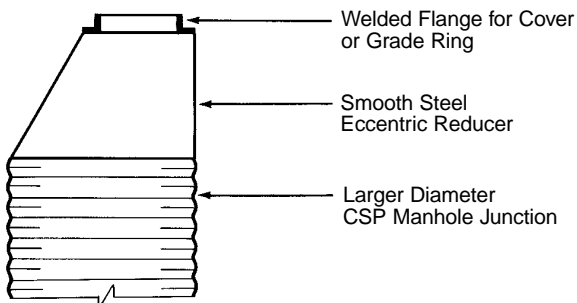
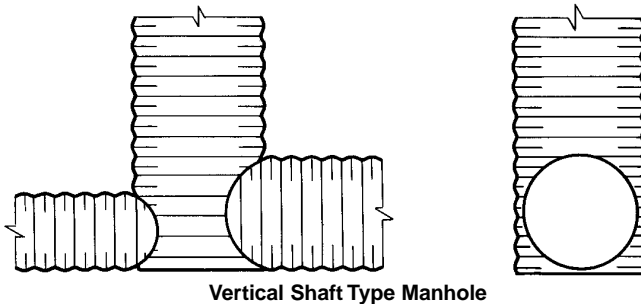
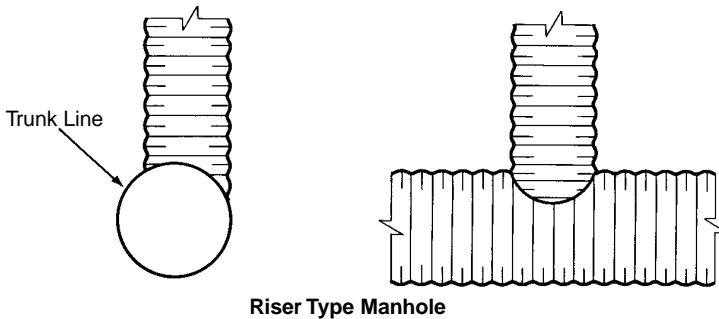

Manhole and Catch Basin Tops

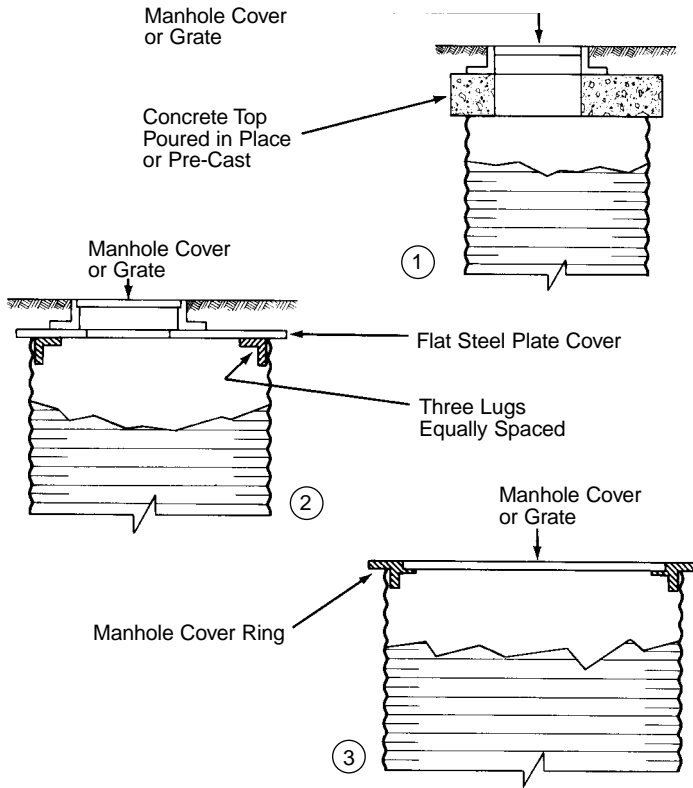

Detail (1) can be used with almost any type of surface cover or grate. Concrete grade ring may be augmented with brick to raise cover elevation in the future. Alternatively, added concrete may be poured. Direct connections of cast or fabricated plates or rings as in (2) and (3) are particularly suitable for grated inlet openings.



Standard cast iron covers and/or steel grates are used with CSP manholes and catch basins.

Manhole Reinforcing

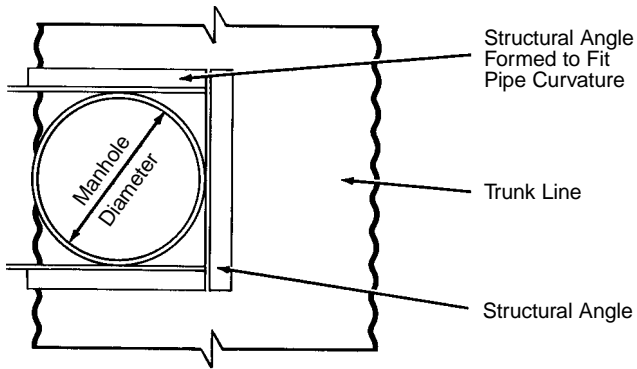

Use of manhole reinforcing may be required, particularly for larger diameters.

Manhole Slip Joints

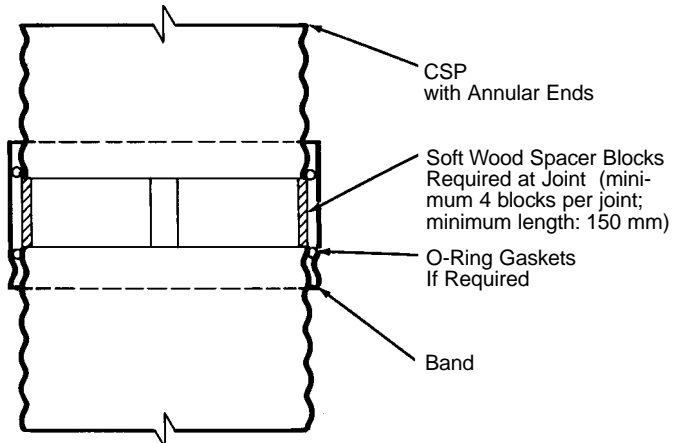

Heavily loaded manholes sometimes make slip joints desirable. Shown above is one method of providing a slip joint, which allows settlement in the riser.

Manhole Ladder

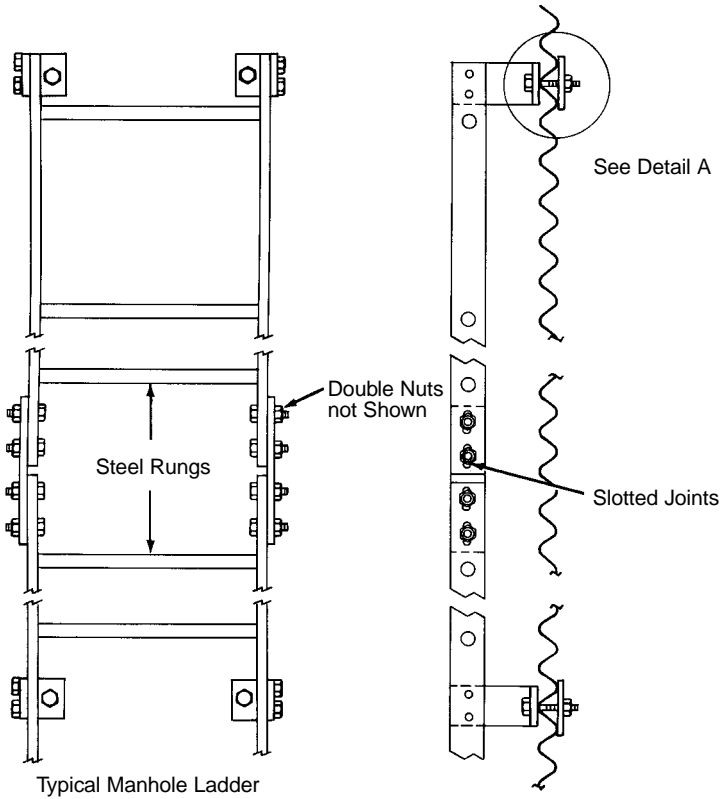

Typical Manhole Ladder

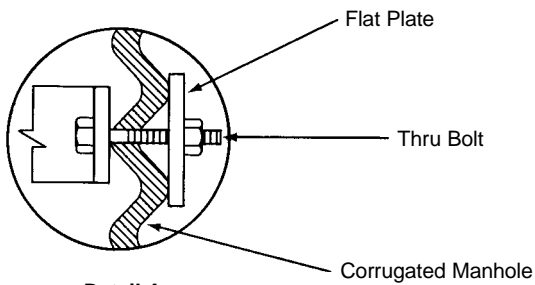

Detail A
Typical Ladder Bracket Attachment

1. Ladder may be constructed in one length.
2. Use bolts with double nuts to connect splice plate at ladder joint to allow vertical movement.
3. Hot-dip galvanizing of all ladder components is recommended.

Manhole Steps

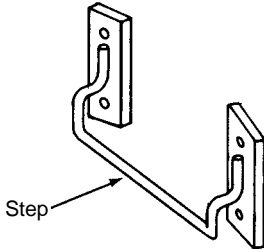
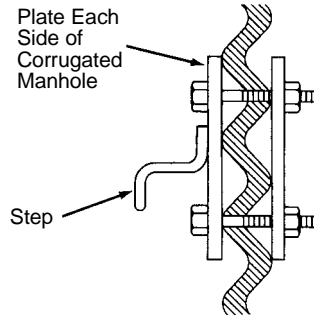
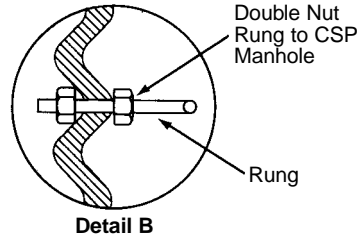
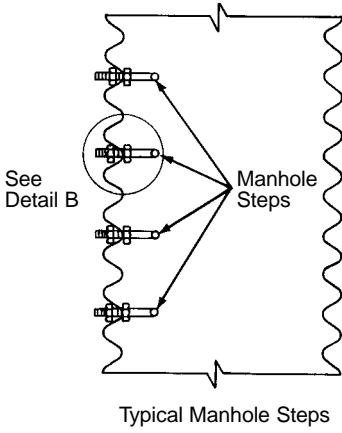

Alternate Methods for Attaching Manhole Steps



CSP catch basin with concrete slab and standard cast-iron frame and cover.

CSP Slotted Drain Inlets

By welding a narrow section of grating in the top of a corrugated steel pipe, a continuous grate inlet is achieved. Originally conceived to pick up sheet flow in roadway medians, parking lots, airports, etc., this product has proven even more useful in curb inlets.



CSP concrete-lined pipe.

CSP Concrete-Lined Pipe

The interior lining of the corrugated steel pipe is composed of an extremely dense, high strength concrete. The lining provides a superior wearing surface for extended structure life as well as a smooth interior for improved hydraulics.



Spiral Rib Steel Pipe

Spiral rib pipe is manufactured from a continuous strip of metallic-coated steel passed through a forming line that forms the external ribs and prepares the edges. The formed section is then helically wound into pipe and the edges are joined by lock seaming. The finished product has the structural characteristics needed for installation and a smooth interior for improved hydraulics.



Spiral rib pipe installation.

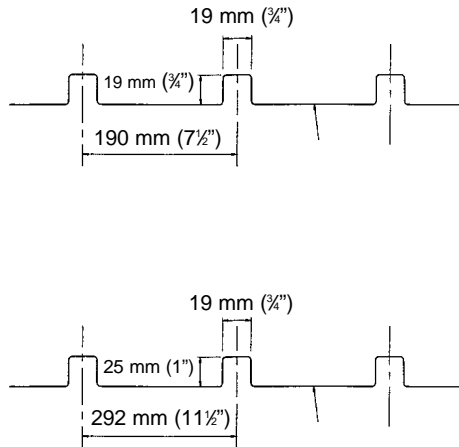

Double Wall (steel lined)

Double wall (steel lined) is a smooth interior corrugated steel pipe fabricated in full circular cross section with a smooth steel liner and helically corrugated shell integrally attached at helical lock seams from the end of each length of pipe. The smooth steel interior lining provides for improved hydraulics.



Lengths of pipe-arch are easily moved into position.

PIPE MATERIALS, PROTECTIVE COATINGS, LININGS AND PAVINGS

Sheets and Coils

Corrugated steel pipe is fabricated from steel sheets or coils conforming to national specifications. The base metal is mill coated with one of several metallic or non-metallic coatings or a combination thereof.

a) Metallic Coatings

Most CSP sheets and coils have a zinc coating. Other metallic coatings using aluminum or aluminum-zinc alloys are also available.

b) Non-Metallic Coatings

Sheets and coils are available mill coated with non-metallic coatings.

- 1) Various polymer films or liquids are applied to one or both sides of the metal.
- 2) Fibers are embedded in the molten metallic coating.

Pipe

Fabricated pipe may be bituminous coated, bituminous coated and invert paved, and/or bituminous coated and fully paved. The pipe may be fully lined with bituminous material, concrete, or specially fabricated smooth with external ribs, or an integral smooth steel inner shell.



Placing coated CSP sewer section. Fabric sling protects pipe coating.

Table 1.16 Material Description and Specifications

Material	Description	Specifications	
		AASHTO	ASTM
Zinc Coated Sheets & Coils	Steel base metal* with 610 g/m ² (2 oz/ft ²) zinc coating	M-218	A929M
Polymer Coated Sheets and Coils	Polymer coatings applied to sheets* and coils* 0.25 mm (0.010 in.) thickness each side	M-246	A742M
Fiber Bonded Coated Sheets	Steel base metal with zinc coating and fibers pressed into the zinc while molten to form fiber bonded coating	–	A885
Aluminum Coated Coils	Steel base metal* coated with 305 g/m ² (1 oz/ft ²) of pure aluminum	M-274	A929M
Sewer and Drainage pipe	Corrugated pipe fabricated from any of the above sheets or coils. Pipe is fabricated by corrugating continuous coils into helical form with lockseam or welded seam, or by rolling annular corrugated mill sheets and riveting seams: 1. Galvanized corrugated steel pipe 2. Polymeric pre-coated sewer and drainage pipe 3. Fiber bonded impregnated corrugated steel pipe 4. Aluminized corrugated steel pipe 5. Structural plate pipe	M-36 M-245 – M-36 M-167	A760M A762M A760M A760M A761M
Asphalt Coated Steel Sewer Pipe	Corrugated steel pipe of any of the types shown above with a 1.3 mm (0.0050 in.), high purity asphalt cover	M-190	A849 A862
Invert Paved Steel Sewer Pipe	Corrugated steel pipe of any one of the types shown above with an asphalt pavement poured in the invert to cover the corrugation by 3.2 mm (1/8 in.)	M-190	A849 A862
Fully Lined Steel Sewer Pipe	Corrugated steel pipe of the types shown above: 1. With an internal asphalt lining centrifugally spun in place 2. Corrugated steel pipe with a single thickness of smooth sheet fabricated with helical ribs projected outward 3. With an internal concrete lining in place 4. Corrugated steel pipe with a smooth steel liner integrally formed with the corrugated shell	M-190 M-36 M-36 M-36	A849, A862 A760M A849, A979M A760M
Cold Applied Bituminous Coatings	Fibrated mastic or coal tar base coatings of various viscosities for field or shop coating of corrugated pipe or structural plate	M-243	A849
Gaskets and Sealants	1. Standard O-ring gaskets 2. Sponge neoprene sleeve gaskets 3. Gasketing strips, butyl or neoprene 4. Mastic sealant	– –	D1056 C361

Notes: *Yield point – 230MPa (33 ksi) min.; tensile strength – 310MPa (45 ksi) min.; elongation (50 mm/ 2 in.) – 20% min.



CSP sewer designed for very wide trenches.